

Signal Connector (Cable 1.5m)			
1	10-30VDC	7	---
2	0V	8	---
3	Tool clamping	9	---
4	Tool unclamping	10	PT100 (bearing)
5	clamping without tool	11	Shield
6	Speed	12	PT100 (bearing)

Power Connector (Cable 1.5m)			
1	PTC130	+	---
2	PTC130	-	---
U	phase U	⊖	GND
V	phase		
W	phase		

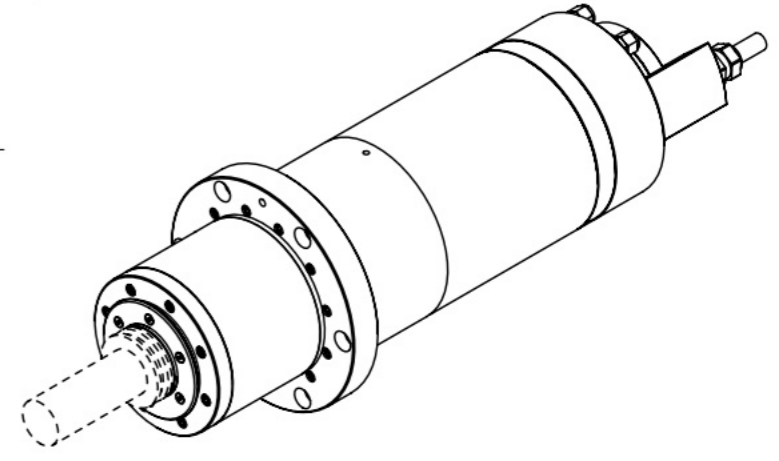
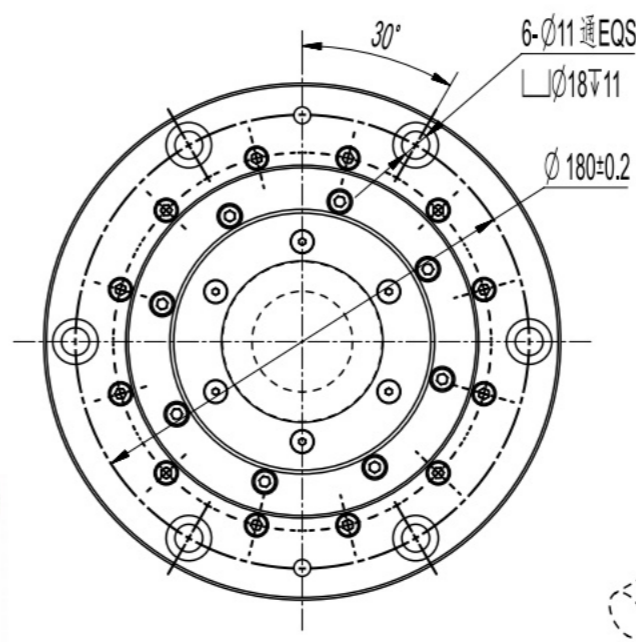

Spindle specification

SPEED	3000	6000	9000	18000	r/min
Frequency	100	200	300	600	Hz
Power(S1)	9	18	18	18	kW
Torque(S1)	29	29	19	8.5	Nm
Voltage	133	260	380	380	V
Current(S1)	52	51	37	33	A
Motor type	Induction motor				
Lubricant	Grease		Rotation	right and left	
Operating position	hori. ontal to vertical		Front seal	Protecting air flow, 1-1.5bar	
ATC cylinder	hydraulic pressure unclamp 80bar, air pressure clamp 5bar				
Interface	SK 40 DIN69871, Pull force great than 8000N				
Air quality	Filtration and drying, particle size 5 microns, residual oil content 0.5mg/m ³				
Spindle Coolant	Water, flow rate 5L/min@25°C				

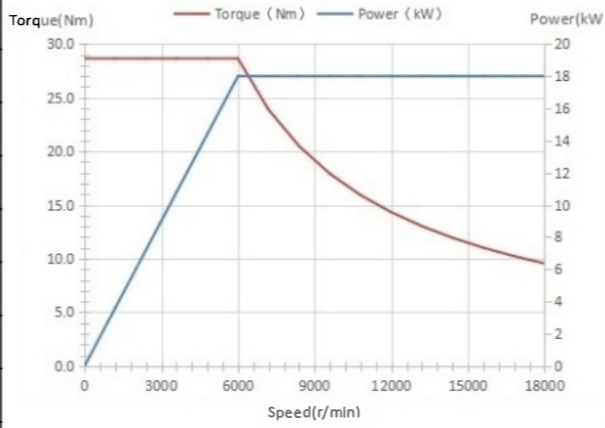

未注尺寸公差	-	主轴外形图		件号	名称	数量	材料	硬度	备注
注: 孔取(+), 轴取(-)									
尺寸/mm									
大于	至	公差							
-	6	±0.05							
6	30	±0.10							
30	120	±0.15							
120	250	±0.25							
250	500	±0.35							
500	1000	±0.45							
1000	1600	±0.55							
1600	2000	±0.65							
更改号	签字	日期							

LYJSD 160XDJ18G18

设计	比例	重量
校对	1:3	-
标准化审核		
工艺会签		
审核		
批准		